



The Enclosure & Instrument  
Case Designer & Manufacturer

## Panel instrument cases DIN 43700 / IEC 61554



...the perfect shell for valuable electronics

## PERANCEA LTD

Unit 36, Silicon Business Centre, 28 Wadsworth Road,  
Perivale, Greenford, UB6 7JZ, England

Tel: +44 (0) 20 8365 2520 Fax: +44 (0) 20 8566 7217

Email: [sales@perancea.com](mailto:sales@perancea.com) Website: [www.perancea.com](http://www.perancea.com)



The Enclosure & Instrument  
Case Designer & Manufacturer

## Switching and control panel (switchboard) instrument cut outs

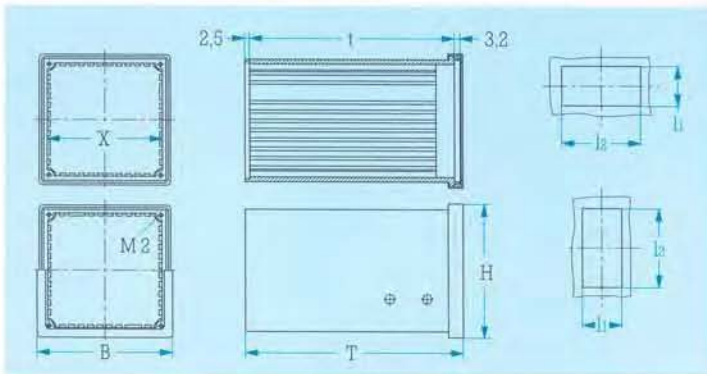

*Specification for a switchboard cut-out for a rectangular case with front frame where B = 96mm and H = 192mm, to be built in vertically:*

*Cut-out 96 x 192 DIN 43700/IEC61554*

Type	H	B	l <sub>1</sub>	Permitted tolerance	l <sub>2</sub>	Permitted tolerance
Square	48	48	45	+0,6	45	+0,6
	72	72	68	+0,7	68	+0,7
	96	96	92	+0,8	92	+0,8
	144	144	138	+1,0	138	+1,0
	192	192	186	+1,1	186	+1,1
Rectangular	48	24	45	+0,6	22,2	+0,3
	72	24	68	+0,7	22,2	+0,3
	96	24	92	+0,8	22,2	+0,3
	72	36	68	+0,7	33	+0,6
	96	48	92	+0,8	45	+0,6
	144	72	138	+1,0	68	+0,7
	144	96	138	+1,0	92	+0,8
	192	96	186	+1,1	92	+0,8
	192	144	186	+1,1	138	+1,0
	288	144	282	+1,1	138	+1,0

*Specification for a switchboard cut-out for a rectangular case with front frame where H = 192mm and B = 96mm, to be built in horizontally:*

*Cut-out 192 x 96 DIN 43700/IEC61554*



# PERANCEA LTD

Unit 36, Silicon Business Centre, 28 Wadsworth Road,  
Perivale, Greenford, UB6 7JZ, England

Tel: +44 (0) 20 8365 2520 Fax: +44 (0) 20 8566 7217

Email: sales@perancea.com Website: www.perancea.com



**PERANCEA**  
The Enclosure & Instrument  
Case Designer & Manufacturer



## DIN Panel Instrument Cases

### Ordering Information

48 x 24mm ~ 96 x 72mm

Size (mm)

B	H	T (ca.)	t (ca.)	1	2	3	4	5	6	7	8	9	10	11	12	13	14
48	24	60.0	53.0	Case DIN 43 700 / IEC 61554	Panel-Clip DIN 43 700 / IEC 61554	Front panel Aluminium 1.5 mm	Cover plate Aluminium 1.5 mm	Filter Screen	Rear wall closed	Rear wall with slots	Rear wall for terminals	Sealing between case and panel	Sealing behind front panel	Transparent door with lock	Transparent door with sash fastener	Packing	
		82.5	75.5	445-440	440-001	441-440	445-451	445-452-xx	445-453-01	445-453-02	445-453-03	445-135-01	445-135-02				
		107.0	100.0	445-441	440-005	441-441	445-130	445-132-xx	445-133-01	445-133-02	445-133-03						
				445-444	440-009	441-444											
48	48	60.5	53.5	445-120	440-001	441-120	445-130	445-132-xx	445-133-01	445-133-02	445-133-03	445-135-01	445-135-02				
		82.5	75.5	445-121	440-005	441-121											
		116.5	109.5	445-122	440-009	441-122											
		138.5	131.5	445-123	440-009	441-123											
		107.0	100.0	445-124	440-009	441-124											
		163.0	156.0	445-125	440-009	441-125											
72	24	60.0	53.0	445-420	440-001	441-420	445-431	445-432-xx	445-433-01	445-433-02							
		82.5	75.5	445-421	440-005	441-421											
		107.0	100.0	445-424	440-009	441-424											
72	36	60.5	53.5	445-040	440-001	441-040	445-050	445-052-xx	445-053-01	445-053-02	445-053-03	445-055-01					
		82.5	75.5	445-041	440-005	441-041											
		116.5	109.5	445-042	440-009	441-042											
		107.0	100.0	445-044	440-009	441-044											
72	48	60.5	53.5	445-140	440-001	441-140	445-150	445-152-xx	445-153-01	445-153-02							
		82.5	75.5	445-141	440-005	441-141											
		116.5	109.5	445-142	440-009	441-142											
		107.0	100.0	445-144	440-009	441-144											
72	72	60.5	53.5	445-220	440-001	441-220	445-230	445-232-xx	445-233-01	445-233-02	445-233-03	445-235-01	445-235-02	446-030-01	446-030-02		
		82.5	75.5	445-221	440-005	441-221											
		116.5	109.5	445-222	440-009	441-222											
		138.5	131.5	445-223	440-009	441-223											
		107.0	100.0	445-224	440-009	441-224											
		163.0	156.0	445-225	440-009	441-225											
		209.0	201.0	445-226	440-009	441-226											
96	24	60.5	53.5	445-100	440-001	441-100	445-111	445-112-xx	445-113-01	445-113-02							
		82.5	75.5	445-101	440-005	441-101											
		116.5	109.5	445-102	440-009	441-102											
		107.0	100.0	445-104	440-009	441-104											
96	48	60.5	53.5	445-180	440-001	441-180	445-170	445-172-xx	445-173-01	445-173-02	445-173-03	445-175-01	445-175-02	446-090-01	446-090-02	445-996	445-996
		82.5	75.5	445-161	440-005	441-161										445-997	445-997
		116.5	109.5	445-162	440-009	441-162										445-997	445-997
		138.5	131.5	445-163	440-009	441-163										445-996	445-996
		107.0	100.0	445-164	440-009	441-164										445-997	445-997
		163.0	156.0	445-165	440-009	441-165										445-996	445-996
96	48	60.5	53.5	445-780	440-001	441-780	445-170	445-172-xx	445-173-01	445-173-02	445-173-03	445-175-01	445-175-02	446-090-01	446-090-02	445-996	445-996
		82.5	75.5	445-761	440-005	441-761										445-997	445-997
		116.5	109.5	445-762	440-009	441-762										445-997	445-997
		138.5	131.5	445-763	440-009	441-763										445-996	445-996
		107.0	100.0	445-764	440-009	441-764										445-997	445-997
		163.0	156.0	445-765	440-009	441-765										445-996	445-996
96	72	60.5	53.5	445-240	440-001	441-240	445-250	445-252-xx	445-253-01	445-253-02	445-253-03	445-255-01	445-255-02				
		82.5	75.5	445-241	440-005	441-241											
		116.5	109.5	445-242	440-009	441-242											
		138.5	131.5	445-243	440-009	441-243											
		107.0	100.0	445-244	440-009	441-244											
		163.0	156.0	445-245	440-009	441-245											
		209.0	201.0	445-246	440-009	441-246											

**PERANCEA LTD**

Unit 36, Silicon Business Centre, 28 Wadsworth Road, Perivale, Greenford, UB6 7JZ, England

Tel: +44 (0) 20 8365 2520 Fax: +44 (0) 20 8566 7217  
Email: sales@perancea.com Website: www.perancea.com





**PERANCEA**  
The Enclosure & Instrument  
Case Designer & Manufacturer



## DIN Panel Instrument Cases

### Ordering Information

192 x 72mm ~ 288 x 144mm

Size (mm)

B	H	T (ca.)	t (ca.)	1	2	3	4	5	6	7	8	9	10	11	12	13	14		
192	72	60.5	53.5	Case DIN 43 700 / IEC 61554	Fixing / Screws DIN 43 700 / IEC 61554	Panel-Clip DIN 43 700 / IEC 61554	Front panel Aluminum 1.5 mm	Cover plate Aluminum 1.5 mm	Filter Screen	Rear wall closed	Rear wall with slots	Rear wall for terminals	Sealing between case and case and panel	Sealing behind front panel	Transparent door with lock	Transparent door with sash fastener	Packing		
		82.5	75.5	445-280	440-001	441-280	445-290	445-291	445-292-xx	445-293-01	445-293-02	445-295-01	445-295-02						
		116.5	109.5	445-281	443-001	441-281													
		138.5	131.5	445-282	443-002	441-282													
		107.0	100.0	445-283		441-283													
		163.0	156.0	445-284		441-284													
		209.0	201.0	445-285		441-285													
				445-286		441-286													
192	96	60.5	53.5	445-340	440-001	440-001	445-350	445-351	445-352-xx	445-353-01	445-353-02	445-355-01	445-355-02	446-110-01	446-110-02		445-989		
		82.5	75.5	445-341	443-001	443-001													
		116.5	109.5	445-342	443-002	443-002													
		138.5	131.5	445-343															
		107.0	100.0	445-344															
		163.0	156.0	445-345															
		209.0	201.0	445-346															
192	144	60.5	53.5	445-380	440-001	440-001	445-390	445-391	445-392-xx	445-393-01	445-393-02	445-393-03	445-395-01	445-395-02	446-120-01	446-120-02			
		82.5	75.5	445-381	443-001	443-001													
		116.5	109.5	445-382	443-002	443-002													
		138.5	131.5	445-383															
		107.0	100.0	445-384															
		163.0	156.0	445-385															
		209.0	201.0	445-386															
288	72	60.5	53.5	445-460	440-001	441-460	445-470	445-471	445-472-xx	445-473-01									
		82.5	75.5	445-461	443-001	441-461													
		116.5	109.5	445-462	443-002	441-462													
		138.5	131.5	445-463		441-463													
		107.0	100.0	445-464		441-464													
		163.0	156.0	445-465		441-465													
		209.0	201.0	445-466		441-466													
288	96	60.5	53.5	445-600	440-001		445-610	445-611	445-612-xx	445-613-01									
		82.5	75.5	445-601	440-005														
288	144	60.5	53.5	445-480	440-001	441-480	445-490	445-491	445-492-xx	445-493-01			445-495-01		446-130-01	446-130-02			
		82.5	75.5	445-481	443-001	443-001													
		116.5	109.5	445-482	443-002	443-002													
		138.5	131.5	445-483															
		107.0	100.0	445-484															
		163.0	156.0	445-485															
		209.0	201.0	445-486															

**PERANCEA LTD**

Unit 36, Silicon Business Centre, 28 Wadsworth Road, Perivale, Greenford, UB6 7JZ, England

Tel: +44 (0) 20 8365 2520 Fax: +44 (0) 20 8566 7217  
Email: sales@perancea.com Website: www.perancea.com



**The Enclosure & Instrument  
Case Designer & Manufacturer**

Transparent doors



**Material: Polycarbonate**

- High strength, ductility and hardness glassfibre reinforced door frames
- Best electrical and dielectric properties
- Excellent door transparency
- Dimensionally stable
- High temperature stability acc. to DIN 53461, 135°C
- Self extinguishing acc. to UL 94 V-0



**Transparent door  
with mounting brackets**

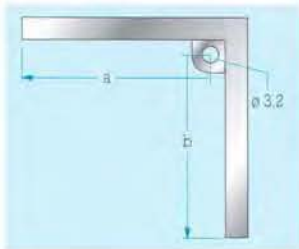

**Flat transparent door  
with mounting brackets**

**flat type  
only 10 mm!**

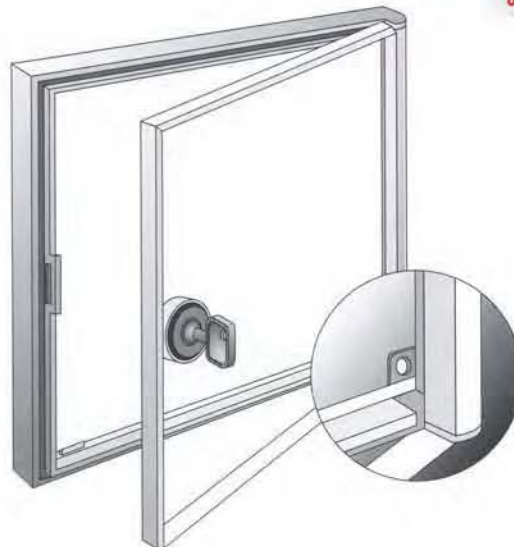
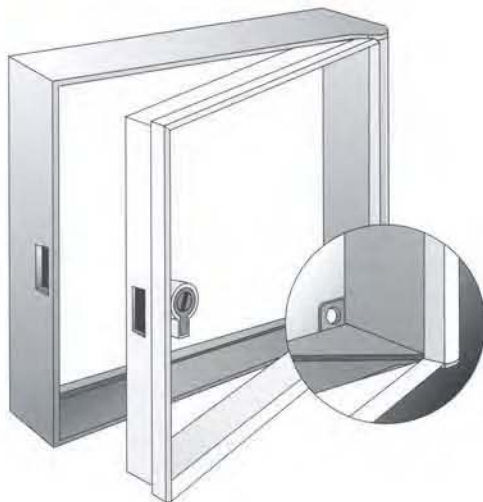

Dimensions DIN 43700	Transparent door			Flat transparent door		
	with lock	with sash fastener	drilling positions a x b	with lock	with sash fastener	drilling positions a x b
144 x 144	446-050-04	446-050-05	125,9 x 125,3	447-050-04	447-050-05	125,5 x 125,5
72 x 144	446-100-04	446-100-05	52,5 x 125,6			
96 x 96	446-040-04	446-040-05	77,2 x 76,8			
96 x 144	446-150-04	446-150-05	76,9 x 125,1			
96 x 48	446-090-04	446-090-05	76,9 x 28,8			
192 x 96	446-110-04	446-110-05	173,3 x 76,9			
192 x 144	446-120-04	446-120-05	173,3 x 125,1			
288 x 144	446-130-04	446-130-05	269,5 x 125,1			
72 x 72	446-030-04	446-030-05	51,6 x 51,3			

# PERANCEA LTD

Unit 36, Silicon Business Centre, 28 Wadsworth Road,  
Perivale, Greenford, UB6 7JZ, England

Tel: +44 (0) 20 8365 2520 Fax: +44 (0) 20 8566 7217

Email: sales@perancea.com Website: www.perancea.com



The Enclosure & Instrument  
Case Designer & Manufacturer

Transparent doors 

**Transparent door  
for switchboard and control  
instrument cases acc. to  
DIN 43700,  
protective system IP42**

**Delivery:**

Transparent door with built-in lock and fitted rubber seal in the door frame.

**Characteristics:**

- Transparent door with moulded frame
- Both door and frame are made by injection moulding thus assuring an exact fit, an optimal choice of a material which is very strong and with no risk of corrosion
- Perfect seal-protective system IP 42 acc. to DIN 40050 provided by all-round soft rubber seal in the moulding
- No loss of space for the equipment front panels
- Due to the special door mountings, the door does not swing in or out sideways on opening
- Door-frame and front-frame can be exchanged. So you have the same basic case with or without door. Advantage for the logistics
- The ready-assembled units cannot be opened by unauthorised persons without using force or special equipment
- Lockable with security key
- Lockable with sash fastener

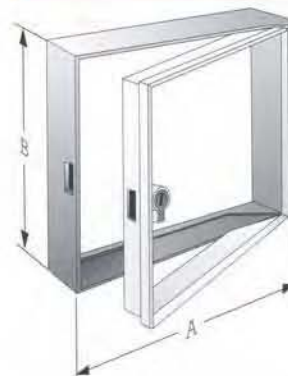
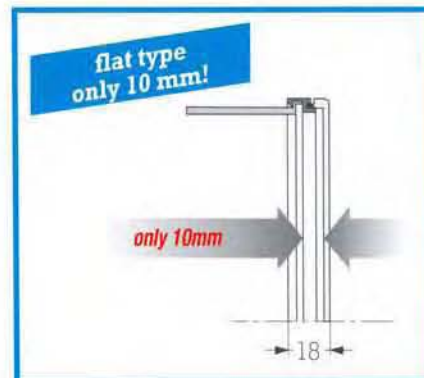

**Flat transparent door**  
for panel instrument cases DIN 43700  
and for front panel mounting IP 42

Door and frame for plastic cases

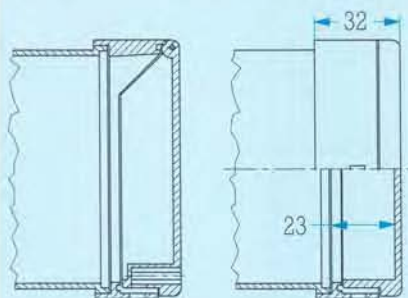

Door and frame for  
sheet steel cases

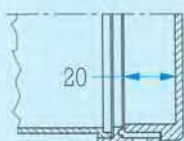

Dimensions DIN 43700 A x B	Transparent door with lock	Transparent door with sash fastener	Flat transpa- rent door with lock	Flat transpa- rent door with sash fastener
144 x 144	446-050-01	446-050-02	447-050-01	447-050-02
72 x 144	446-100-01	446-100-02		
96 x 96	446-040-01	446-040-02		
96 x 144	446-150-01	446-150-02		
96 x 48	446-090-01	446-090-02		
192 x 96	446-110-01	446-110-02		
192 x 144	446-120-01	446-120-02		
288 x 144	446-130-01	446-130-02		
72 x 72	446-030-01	446-030-02		

# PERANCEA LTD

Unit 36, Silicon Business Centre, 28 Wadsworth Road,  
Perivale, Greenford, UB6 7JZ, England

Tel: +44 (0) 20 8365 2520 Fax: +44 (0) 20 8566 7217

Email: sales@perancea.com Website: www.perancea.com

